

 **CORGI**

A224 - A224A

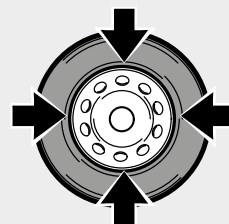

24''



14''



Versione con discesa automatica del braccio
Version with automatic lowering of the head arm



Smontagomme automatico con palo ribaltabile pneumaticamente



Automatic tyre changer with pneumatic tilting column





A richiesta: disponibile nella versione DV e con sistema di intallatura e gonfiaggio T.I..
On request: available in DV version and with T.I. inflation system and alloy spot rims.

1 PALO PORTA BRACCIO - ARM SUPPORT COLUMN

PALO PORTA BRACCIO ribaltabile pneumaticamente ad elevata rigidità torsionale in tutte le posizioni di lavoro.

PNEUMATICALLY-OPERATED TILTING ARM SUPPORT COLUMN with high torsional rigidity, can be tilted in any working position.

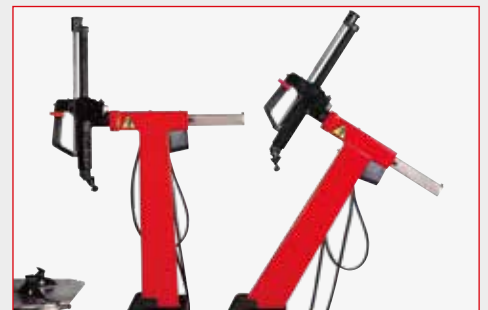

2 BRACCIO ORIZZONTALE - HORIZONTAL ARM



Braccio orizzontale (esagonale) telescopico per un rapido posizionamento della torretta rispetto al cerchio.

Telescopic (hexagonal) horizontal arm for quicker positioning of the head in relation to the rim

3 APPOGGI SCORREVOLI SLIDING SUPPORTS



Appoggi scorrevoli con punte di bloccaggio intercambiabili. Griffe in fusione più alte per un miglior bloccaggio del cerchio dall'interno e dall'esterno.

Sliding supports with interchangeable clamping centres. Higher cast clamps for improved rim clamping from inside and outside

4 AUTOCENTRANTE - TURNTABLE



Autocentrante con doppio cilindro pneumatico in grado di bloccare saldamente ogni tipo di cerchio.

Turntable with two pneumatic cylinders able to safely clamp any type of rim

5 TORRETTA - TOOL HEAD



L'utensile di smontaggio e montaggio è una novità pregevole di questo smontagomme. Di nuova concezione, l'aggiunta dell'**ala posteriore**, offre un rilevante supporto durante la fase di montaggio, agevola l'entrata dello pneumatico nel cerchio ed evita potenziali danni allo pneumatico stesso. Sono altresì presenti le protezioni in plastica per evitare segni sui cerchi. Di grande efficacia pure su pneumatici RFT, UHP e BSR in abbinamento al premitallone, disponibile come accessorio.

*The demounting and mounting tool is a major innovation for this tyre changer. The addition of the **newly-designed read tab** offers significant support during mounting step, facilitates tyre installation on the rim and avoids possible damage to the tyre. Plastic protections are also present to avoid scratching the rims. Very effective also on RFT, UHP e BSR tyres in combination with the bead pressing tool, available as accessory.*

6 BLOCCAGGIO PNEUMATICO - PNEUMATIC LOCKING



Bloccaggio pneumatico **simultaneo** del braccio orizzontale e di quello verticale porta torretta con posizionamento automatico di quest'ultima nella posizione ideale di lavoro. **Automatico (A)** e **Manuale (B)**.

*Simultaneous pneumatic locking of the horizontal arm and head carrier vertical arm with automatic positioning of the latter to ideal working position. **Automatic (A)** e **Manual (B)**.*

7 PEDALIERA ESTRAIBILE - EXTRACTABLE PEDAL CONTROL

Pedaliera estraibile, una grande comodità per eventuali ispezioni nell'area comandi.
Extractable pedal controls for easy inspection of control area.

ACCESSORI IN DOTAZIONE - STANDARD ACCESSORIES



DATI TECNICI - TECHNICAL DATA

Autocentrante	Turntable	
Capacità di bloccaggio interno	Inside clamping capacity	13" ÷ 26"
Capacità di bloccaggio esterno	Outside clamping capacity	10" ÷ 24"
Diametro massimo pneumatico	Maximum tyre diameter	1100 mm
Larghezza massima pneumatico	Maximum tyre width	360 mm (14")
Coppia di rotazione	Rotation torque	1200 Nm (400v 3ph)
Velocità di rotazione	Rotation speed	8 rpm - 13 rpm (x 2V)
Stallonatore	Bead breaker	
Apertura massima	Maximum opening	380 mm
Forza paletta	Shoe force	15.500 N
Alimentazione	Power supply	
Tutte le alimentazioni	All power supply	
Pressione di esercizio	Operating pressure	10 bar

DIMENSIONI - DIMENSIONS

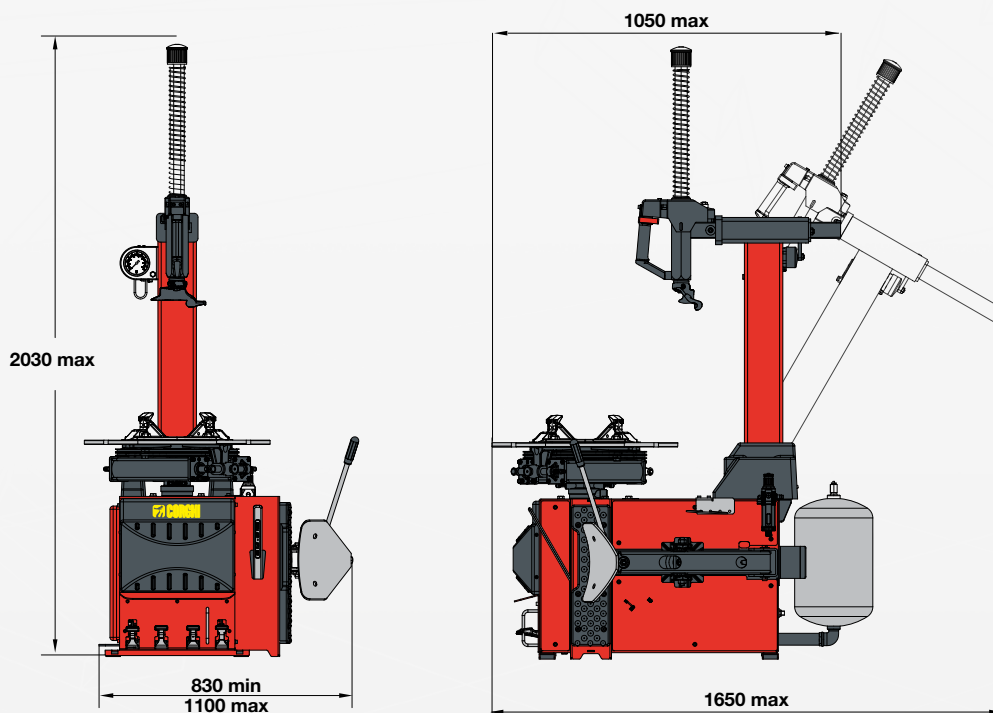

Peso della macchina / Machine weight 235 kg - TI 250 kg



NEXION SPA - www.corghi.com - info@corghi.com

