



ERCO XC5500
ERCO XC4500

C-Line

Lifting equipment



5500 **4500**



Electrohydraulic underwheel scissors type lift 

ERCO XC5500 - XC4500

Electrohydraulic underwheel scissors type lift for total wheel alignment "CT" with:

- rear oscillating platforms and recesses for front turntables.

Auxiliary wheel release lift "LT".

Versions available:

ERCO XC5500 - ERCO XC5500 CT - ERCO XC5500 CT LT

ERCO XC4500 - ERCO XC4500 CT - ERCO XC4500 CT LT

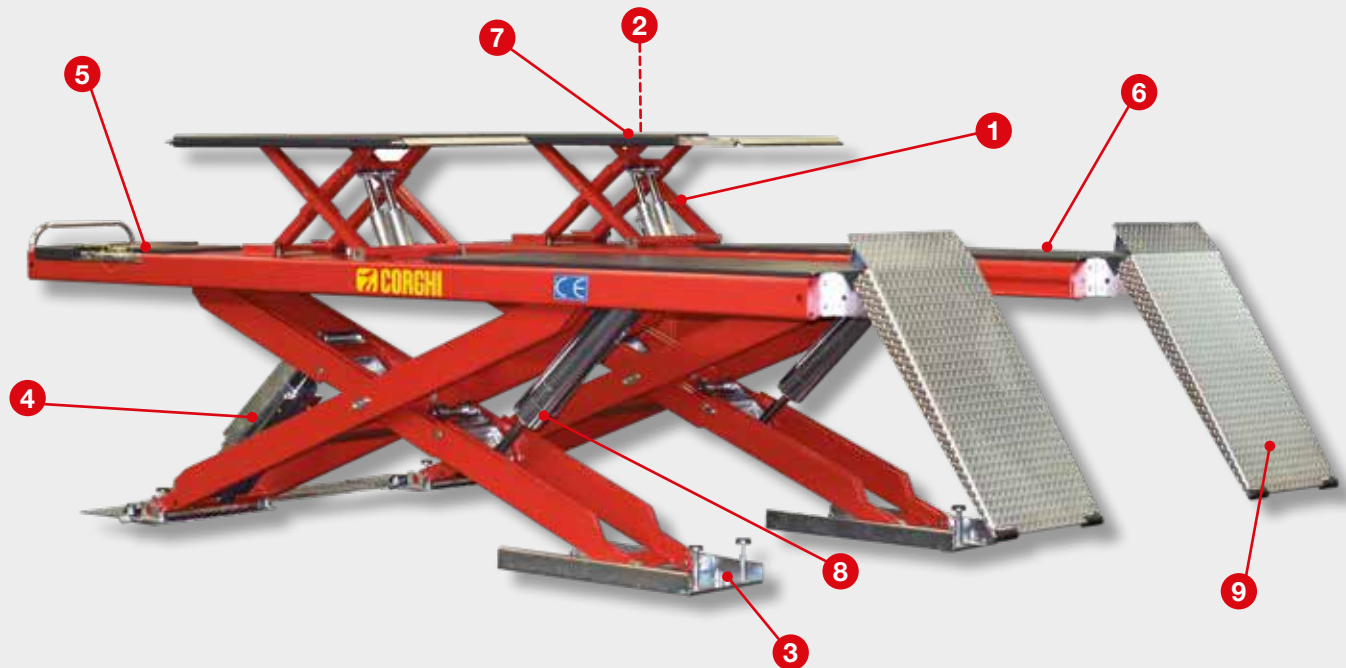

1 LIFT TABLE WITH DOUBLE CYLINDER

Lift table with **double lifting cylinder** to ensure a constant parallel lift movement.



2 CONTROL UNIT

Control unit with few **essential keys** and **clear and intuitive functional icons**.

3 ADJUST THE BASE FRAME

The wheel alignment versions of the range already include the possibility of **adjust the base frame**.





4 ADJUSTABLE MECHANICAL SAFETY DEVICE

Adjustable mechanical safety device, also for exact adjustment for wheel alignment.

5 TURNTABLE

Adjustable recess for the **turntable**.



6 SLIDING PLATES

Sliding plates with air central locking.

7 LIFT TABLE WITH DOUBLE EXTENSIONS

Lift table with double lifting cylinder and double extensions, in front and rear, which is very flexible, no movement of vehicle on the lift needed.

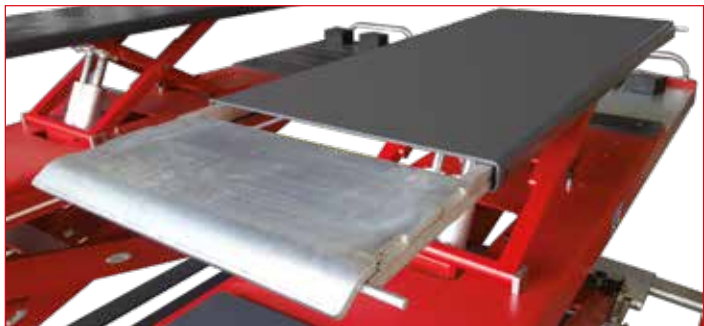

8 DOUBLE LIFTING LEVER

Double lifting lever to ensure a constant parallel lift movement.

9 SHORT RAMPS

Easy drive on with **short and sturdy ramps** due to very low height.



TECHNICAL DATA - ERCO XC5500 - ERCO XC5500 CT - ERCO XC5500 CT LT

Main lift capacity	"LT" capacity	Lifting time	Motor	Main lift max. lifting height	"LT" max. lifting height	Lift minimum height	Runboard length
5500 kg	4000 kg	45 s	400/230V - 3kW 3Ph - 50/60Hz	2010/2030/2090 mm	411 mm	165/185/240 mm	4608/5208 mm

TECHNICAL DATA - ERCO XC4500 - ERCO XC4500 CT - ERCO XC4500 CT LT

Main lift capacity	"LT" capacity	Lifting time	Motor	Main lift max. lifting height	"LT" max. lifting height	Lift minimum height	Runboard length
4500 kg	4000 kg	45 s	400/230V - 3kW 3Ph - 50/60Hz	2010/2030/2090 mm	411 mm	165/185/240 mm	4208 mm

SUPPLIED ACCESSORIES

- Automatic runway levelling system with master/slave hydraulic circuit.
- Self-lubricating bushings on all rotating parts.
- Set of 4 rubber pads.

OPTIONAL ACCESSORIES

- Pair of cross pieces and pads for off-road vehicles.
- Kit for flush installations.

DIMENSIONS

ERCO XC5500 - ERCO XC4500

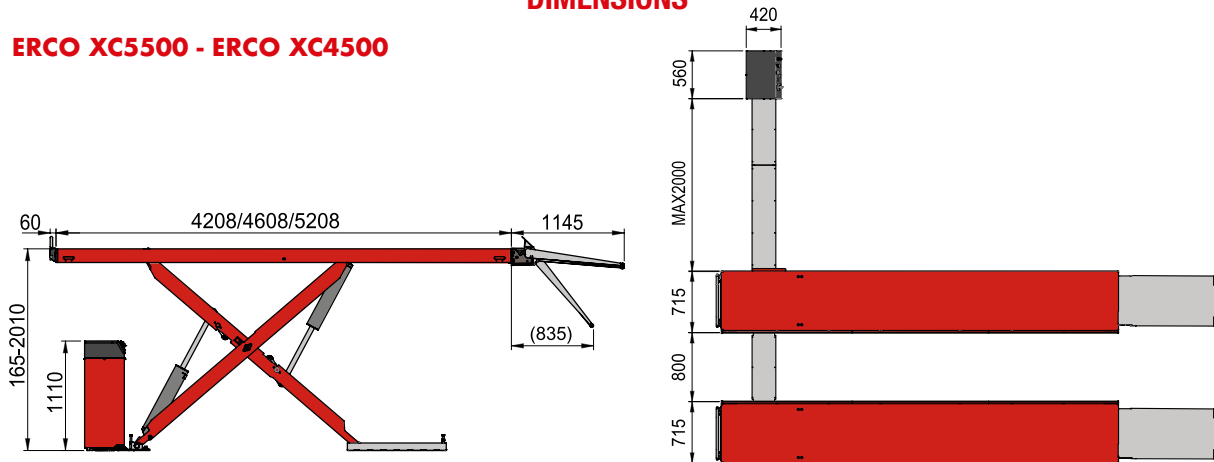

ERCO XC5500 CT - ERCO XC4500 CT

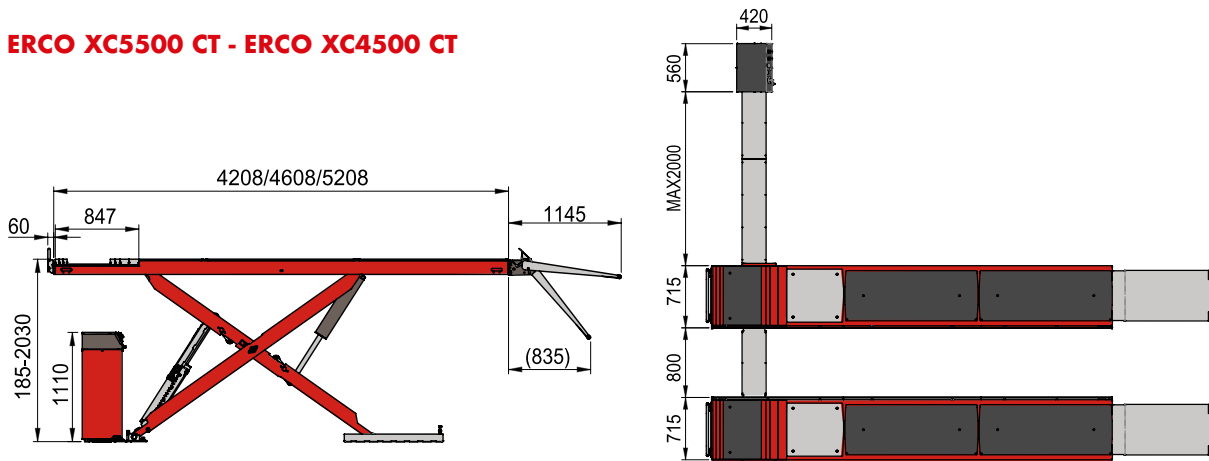

ERCO XC5500 CT LT - ERCO XC4500 CT LT

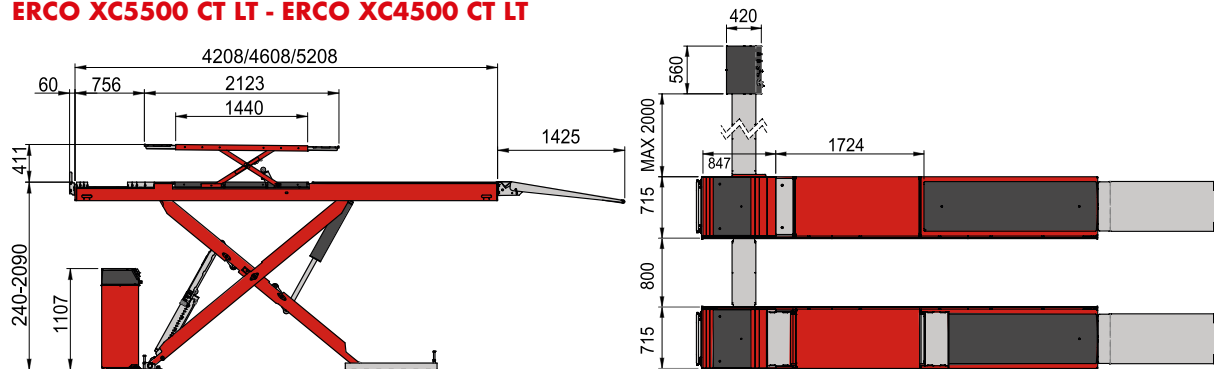

The manufacturer reserves the right to modify the features of its products at any time.
Cod. DPCG000176B - 06/2023

To protect the planet and reduce paper usage, our catalogues are viewable online at the website www.corghi.com. Printing responsibly contributes to saving the environment.



NEXION SPA - www.corghi.com - info@corghi.com



Designed in
ITALY

